



NEAEN LEMARAC
BATCH VACUUM CARMEL COOKER

The NEAEN Lemarac batch vacuum cooker is designed for cooking caramel, toffee mass, condensed milk, fudge, gum base, as well as fillings, jellies and marmalades, and mixes of soft varieties of sweets.

Using a vacuum during the cooking process allows it to reduce the processing time and temperature, which is necessary for adding heat-sensitive ingredients. It is Ideal for cooking light toffee and caramel masses without the browning effect often associated with cooking these types of sweets.

The capability of atmospheric and vacuum cooking makes NEAEN Lemarac the ideal solution for a variety of technological tasks.

ONGOING PROCESSES

- ▶ mixing
- ▶ dissolving
- ▶ pre-cooking
- ▶ cooking
- ▶ caramelising
- ▶ vacuuming
- ▶ tempering



SOFT AND SMOOTH CARAMEL

The design and form of the vacuum cooker was developed in collaboration with leading process engineers with years of practical experience in the production of toffee and caramel masses. This succeeded in achieving the optimal in the processes of moisture removal and caramelization. The finished product has a smooth homogeneous structure.

A system of dosed ingredients to be added is supplied. This is not included in basic supply scope and can be offered as option.

BENEFITS

The high quality of the finished product. Thanks to the special form of the cooking vessel, the processes of moisture removal and caramelisation take place as efficiently as possible, thereby reducing the cooking time of the confectionery mass and therefore improving the quality of the finished product.



Vacuum execution allows cooking and water evaporation at lower temperatures, eliminating scorching and overcooking of the product. The finished product has a natural rich flavor with maximum preservation of flavoring substances. There is also the possibility of adding heat-sensitive ingredients.

Economy. The excellent performance of heat exchange provides rapid heating that significantly reduces energy consumption for cooking in one batch.

Ease of use. Ingredients are conveniently inserted through the top hatch or load fitting. The finished product (thick mass) is conveniently unloaded through the highly hygienic bottom outlet valve.

Hygiene. The design of the vacuum caramel cooker is convenient for cleaning and maintenance. It is highly hygienic, with no dead zones. CIP cleaning.

An automatic control system provides control over all processes in accordance with prescribed recipes.



DESIGN OF NEAEN LEMARAC BATCH VACUUM CARMEL COOKER

The design of the vacuum caramel cooker consists of thermally insulated cylindrical vessel equipped with an agitator with scrapers specially shaped for effective mixing of viscous products and dissolving ingredients. The cooker's cover is equipped with a hatch to insert ingredients, processing fittings according to the customer's specifications. There is also an inspection glass, connecting fittings for CIP system, a vacuum gauge, a vacuum controller and a tap for the condensated vapor.

At the bottom of the vacuum caramel cooker is the specially designed bottom valve (with manual, pneumatic or mechanical drive, with mechanical locking), guaranteeing the absence of a dead zone when unloading the product.

The basic configuration includes a temperature sensor, gauge and torch lights.

The vacuum cooker NEAEN Lemarac comes complete with a vacuum station and condensate recovery system.

The vacuum caramel cooker can be equipped with all necessary equipment to complete the production cycle:

- ▶ Storage tanks for ingredients (syrup, condensed milk ...)
- ▶ Sugar syrup cooking plants
- ▶ Measuring tanks
- ▶ Mixer units
- ▶ Dosers and more.

Model	Lemarac-50	Lemarac -150	Lemarac -300	Lemarac -600	Lemarac -1100	Lemarac -2000
Total volume, l	50	150	300	600	1100	2000
Material	AISI304 / AISI316L					
Heating	Steam, electricity, gas					

Our experience in manufacturing process equipment for the production of caramel, toffee and jelly masses allows us to offer customers full cycle equipment with various levels of automation, including fully automated lines with minimal operator involvement.

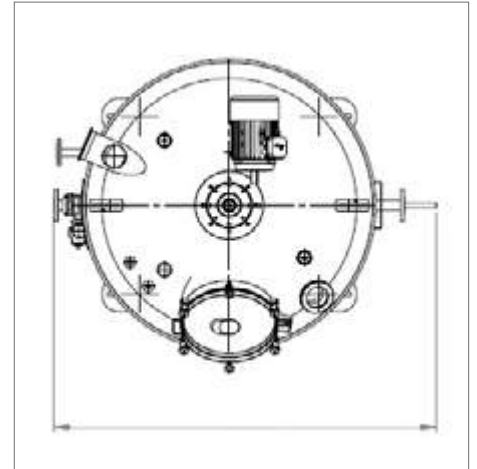
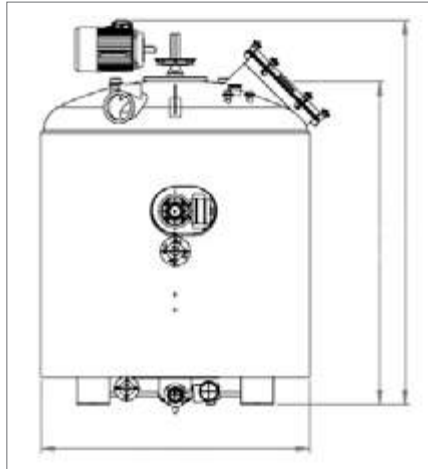
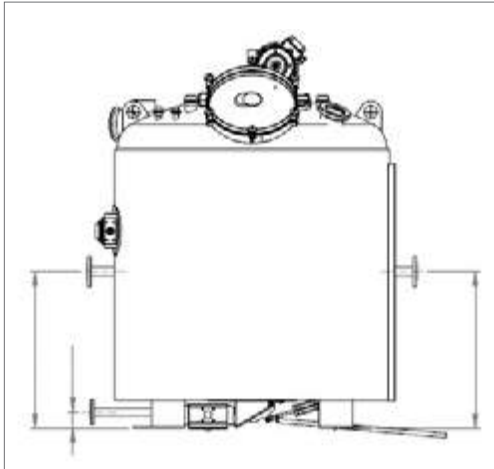

THE EMA EUROPE COMPANY HAS MORE THAN THIRTY YEARS OF EXPERIENCE IN THE DEVELOPMENT, DESIGN, AND MANUFACTURE OF INDUSTRIAL EQUIPMENT FOR THERMAL FOOD PROCESSING

The range of commercially available equipment includes continuous conveyor fryers and ovens, drum fryers, batch blanchers, and continuous drum and conveyor blanchers, defrosters, continuous and batch cookers both atmospheric and vacuum, scraped surface heat exchangers, and a wide range of auxiliary equipment such as washers, conveyors, pumps, homogenizers, and others.

Our company offers a complete cycle service from design of technology projects to the manufacturing of equipment of any complexity in our own production site, located in the heart of Europe, as well as the introduction of the equipment in operation, upholding the warranty and after-warranty service with our own service center.

Having much experience in the practical implementation of projects in the industrial processing of meat, fruit and vegetable products, semi-finished and other products, our company is ready to offer technological consultation, development of the production process of the project, equipment manufacturing, erection supervision, commissioning works, and further maintenance services to its customers.



info@neaen.com

Find your nearest sales representative at

<http://neaen.com/contact-information>